

DATA IMAGE CORPORATION

LCD Module Specification

ITEM NO.: GM322400FNSWC-01

Table of Contents

1. COVER & CONTENTS	1
2. RECORD OF REVISION	2
3. GENERAL SPECIFICATIONS	3
4. ABSOLUTE MAXIMUM RATINGS	4
5. ELECTRICAL CHARACTERISTICS	6
6. ELECTRO-OPTICAL CHARACTERISTIC	6
7. TIMING CHARACTERISTICS	8
8. PIN CONNECTIONS	10
9. POWER SUPPLY	11
10. BLOCK DIAGRAM	12
11. QUALITY ASSURANCE	13
12. LOT NUMBERING SYSTEM	17
13. LCM NUMBERING SYSTEM	17
14. PRECAUTIONS IN USE LCM	18
15. OUTLINE DRAWING	19
16. PACKAGE INFORMATION.....	20

R&D Dept.	Q.C. Dept.	Eng. Dept.	Prod. Dept.
Version:	Issued Date:	Sheet Code:	Total Pages:
	2003/7/31		20

2. RECORD OF REVISION

Rev	Date	Item	Page	Comment

3. GENERAL SPECIFICATION

Display Format : 320 dots (W) × 240 (H) dots
Dot Size : 0.33 (W) × 0.33 (H) mm
View Area : 122 (W) × 92 (H) mm
Outline Dimensions : 167.0 (W) × 109.0 (H) × 10.5 (T) mm Max.
Weight : 200g max.

LCD Type : STN Gray STN FSTN TN

Polarizer mode : Reflective Transflective

Transmissive Negative

View Angle : 6 O'clock 12 O'clock Others _____

Backlight : LED EL CCFL

Backlight Color : Yellow green Amber Blue Green

White Others

Controller / Driver : 79401,79430

Temperature Range : Normal Wide Temperature
Operating 0 to 50°C Operating -20 to 70°C
Storage -20 to 70°C Storage -30 to 80°C

4. ABSOLUTE MAXIMUM RATINGS

4.1 ELECTRICAL ABSOLUTE MAXIMUM RATINGS

 $V_{SS} = 0V, \quad T_a = 25^{\circ}C$

Item	Symbol	Min.	Max.	Unit
Supply Voltage (Logic)	V_{DD-VSS}	0	6.5	V
Supply Voltage (LCD Driver)	$V_{DD-V_{EE}}$	0	35	V
Input Voltage	V_I	V_{SS}	V_{DD}	V
Operating Temperature	T_{OP}	0	50	$^{\circ}C$
Storage Temperature	T_{STG}	-20	70	$^{\circ}C$

4.2 ENVIRONMENTAL ABSOLUTE MAXIMUM RATINGS

Item	Operating		Storage		Comment
	(Min.)	Max.)	(Min.)	(Max.)	
Ambient Temp	0	50	-20	70	Note (1)
Humidity	Note (2)		Note(2)		Without Condensation
Vibration	--	4.9M/S ²	--	19.6M/S ²	XYZ Direction
Shock	--	29.4M/S ²	--	490M/S ²	XYZ Direction

Note(1) $T_a = 0^{\circ}C$: 50Hr Max.

Note(2) $T_a \leq 40^{\circ}C$: 90% RH Max.

$T_a \geq 40^{\circ}C$: Absolute humidity must be lower than the humidity of 90% RH at $40^{\circ}C$.

4.3 Electronic Static Discharge maximum rating

ESD test method : IEC1000-4-2

Item	Description	
Testing environment	Ambient temperature : 15°C to 35 °C Humidity: 30% to 60 % LCM (E.U.T) : Power up	
Testing equipment	Manufacture: Noise Ken, Model No. ESD-100L	
Testing condition	See drawing 1	
Direct discharge	0 to ± 6 KV	Discharge point, see drawing 2
Indirect discharge	0 to ± 12KV	Discharge point, see drawing 1
Pass condition	No malfunction of unit. Temporary malfunction of unit which can be recovered by system reset	
Fail condition	Non. Recoverable malfunction of LCM or system	

FIG 1 ESD TESTING EQUIPMENT

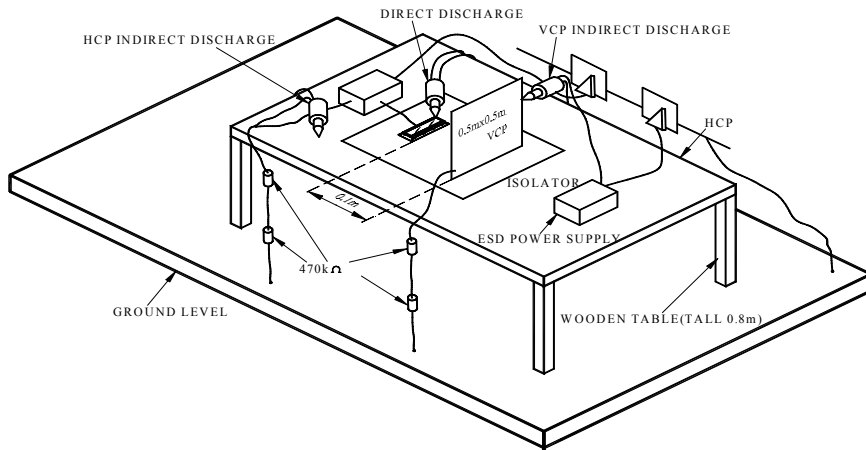

(1)

DIRECT CONTACT DISCHARGE CONTACT POINT : A.B.C.D

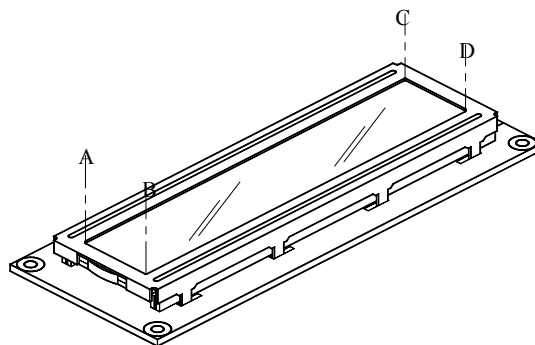

(2)

5. ELECTRICAL CHARACTERISTICS

Item	Symbol	Condition	Min.	Typ.	Max.	Unit
Supply Voltage (Logic)	V _{DD} -V _{SS}		4.5	5.0	5.5	V
Supply Voltage (LCD)	V _{DD} -V _{ADJ}	0°C	23.1	23.6	24.1	V
		25°C	22.1	22.6	23.1	
		50°C	21.1	21.6	22.1	
Input Voltage	V _{IH}	--	0.8*V _{DD}	--	V _{DD}	V
	V _{IL}		V _{SS}	--	0.2*V _{DD}	
Logic Supply Current	I _{DD}	V _{DD} =5V	--	20	--	mA
	I _{EE}	V _{EE} =-20V		15		

6. ELECTRO-OPTICAL CHARACTERISTICS

ITEM	Symbol	Condition	Min.	Typ.	Max.	Unit	Ref.
Rise Time	Tr	0°C	--	340	700	ms	Note (1)
		25°C		130	300		
Fall Time	Tf	0°C	--	370	740	ms	
		25°C		160	320		
Contrast	CR	25°C	5	8	--		Note (3)
View Angle	θ ₁ ~θ ₂	25°C & CR≥5	50	80	--		Note (2)
	∅ ₁ , ∅ ₂		30	45	--		
Frame Frequency	Ff	25°C	--	70	--	Hz	

Note (1) & (2) : See next page

Note (3) : Contrast ration is defined under the following condition:

$$CR = \frac{\text{Brightness of non-selected condition}}{\text{Brightness of selected condition}}$$

- (a). Temperature ----- 25°C
- (b). Frame frequency ---- 70Hz
- (c). Viewing angle ----- θ = 0°, ∅ = 0°
- (d). Operating voltage --- 22.6V

Note (1) Response time is measured as the shortest period of time possible between the change in state of an LCD segment as demonstrated below:

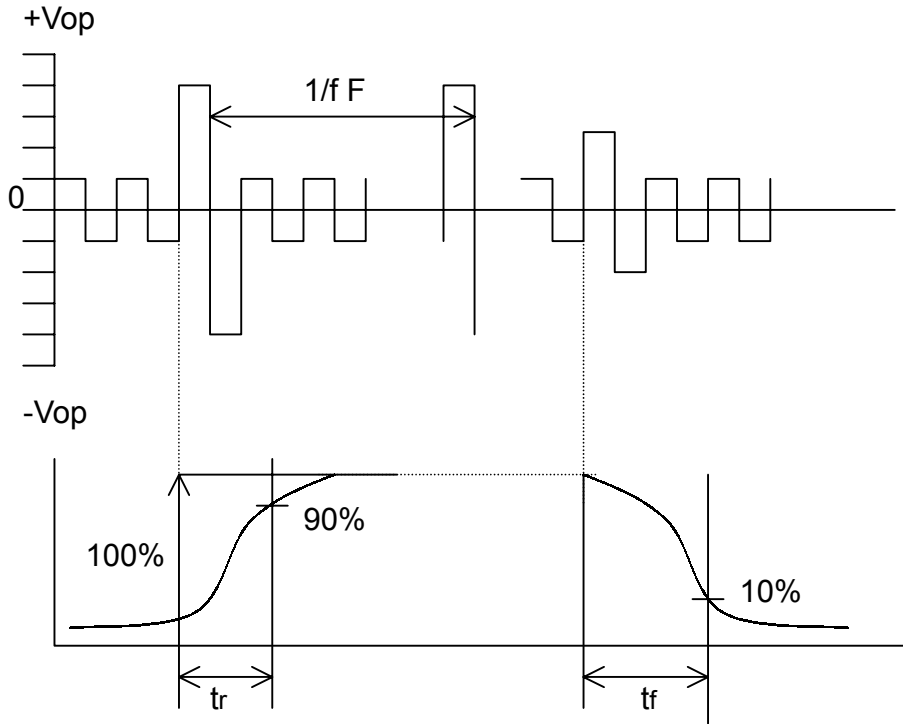

Condition:

- (a) . Temperature -----25C
- (b) . Frame frequency ----- 70Hz
- (c) . View Angle ----- $\theta = 0^\circ$, $\phi = 0^\circ$
- (d) . Operating voltage ----- 22.6V

Note (2) Definition of View Angle

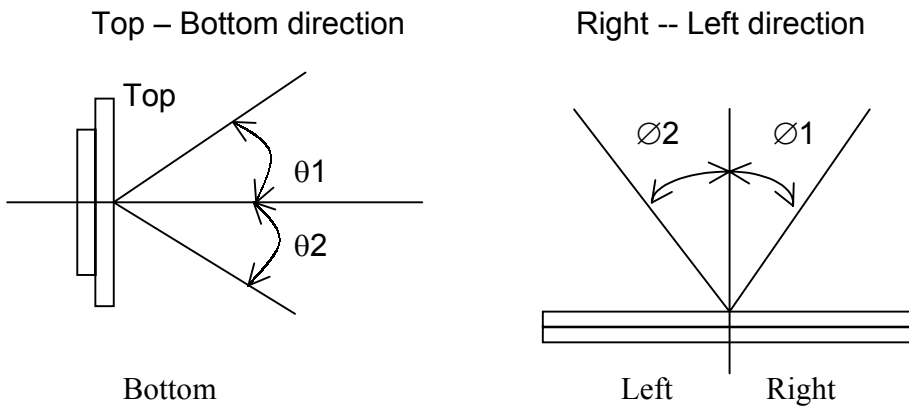

6.1 LED ELECTRO-OPTICAL CHARACTERISTIC

Ta = 25°C

Item	Symbol	Condition	Min.	Typ.	Max.	Unit
Forward Voltage	V _F	IF = 200mA White	--	3.4	--	V
Luminous Intensity	I _v	IF = 200mA White	--	400	--	cd/m ²
Chromaticity	X	IF = 200mA White	0.29	0.31	0.33	nm
	Y		0.30	0.32	0.34	
Spectrum Radiation	Δλ	IF = 200mA White	--	--	--	nm
Reverse Current	I _R	VR = 5V White	--	--	0.2	mA

Note : Measured at the bared LED backlight unit.

6.2 LED MAXIMUM OPERATING RANGE

Item	Symbol	White	Unit
Power Dissipation	PAD	0.68	W
Forward Current	I _{AF}	250	mA
Reverse Voltage	VR	5	V

6.2.1 LED ARRAY BLOCK DIAGRAM

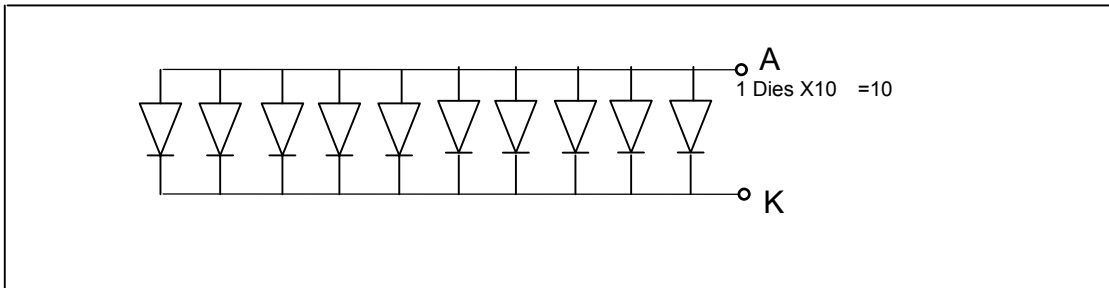

7. TIMING CHARACTERISTIC

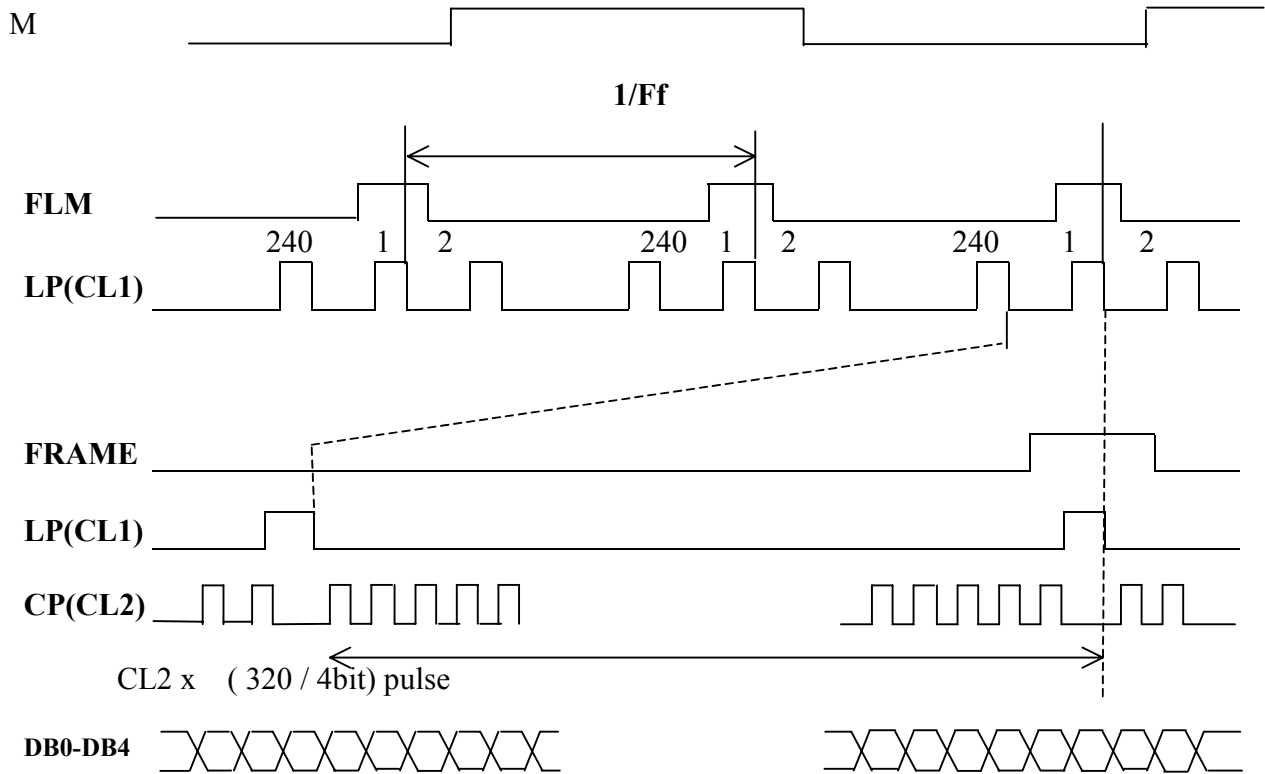

Allowable Operating Ranges at Ta=-20 to+75°C ,VSS=0V

Item	Symbol	Applicable Pins	Min.	Max.	Unit	Note
Input high level voltage	V _{IH}	DB0 to DB3,CP,LP,M,/DISP OFF	0.8 V _{DD}	--	V	--
Input Low level voltage	V _{IL}	DB0 to DB3,CP,LP,M,/DISP OFF	--	0.2 V _{DD}	V	
CP(Shift clock)	t _{CP}	CP	--	6.0	MHZ	--
CP pulse width	t _{WC}	CP	50	--	ns	--
CL1 LP pulse width	t _{WL}	LP	50	--	ns	--
Setup time	t _{SETUP}	DB0 to DB3 →CP	30	--	ns	--
Hold time	t _{HOLD}	DB0 to DB3 →CP	30	--	ns	--
CP and LP rise time	t _R	CP,LP			ns	*4
CP and LP fall time	t _F	CP,LP			ns	*4

Note: 2. V_{DD} ≥ V_I > V₃ > V₄ > V_{EE}

3. When the power is turned on, either the logic system power must be on before the LCD drive system power or else they must both be turned on at the same time, When the power is turned off, either the LCD drive system power must be turned off before the logic system power, or else both must be turned off at the same time.

4. The CP and LP rise time (t_R) and the CP and LP fall time (t_F) must satisfy equations A and B below at the same time

A. $t_R t_F < \frac{1}{2f_{CP}} - t_{WC}$

B. $t_R t_F < 50ns$

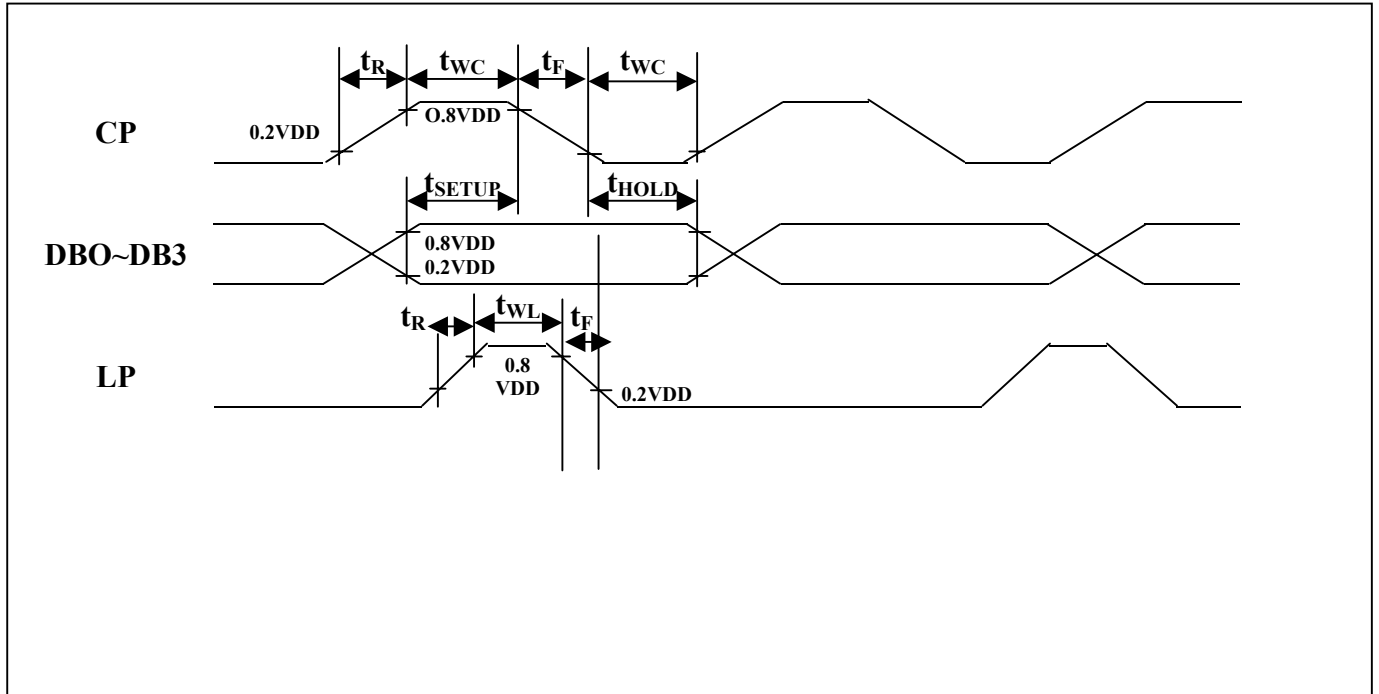

Switching Characteristics Diagram

8. PIN CONNECTIONS

No.	Symbol	Function
1-4	D0-D3	Data bus line 0~3
5	/DISPOFF	Display on/off control, High= ON Low= OFF
6	FLM	First Line Mark
7	N.C (M)	Alternate Signal For LCD Driver
8	LP (CL1)	Data Latch Pulse
9	CP (CL2)	Data Shift Pulse
10	VCC (VDD)	Power Supply For Logic
11	VSS	GND
12	VEE	Power Supply For LCD
13	VADJ (VO)	Input voltage for LCD contrast adjustment
14	FG	Front Panel Ground

9. POWER SUPPLY

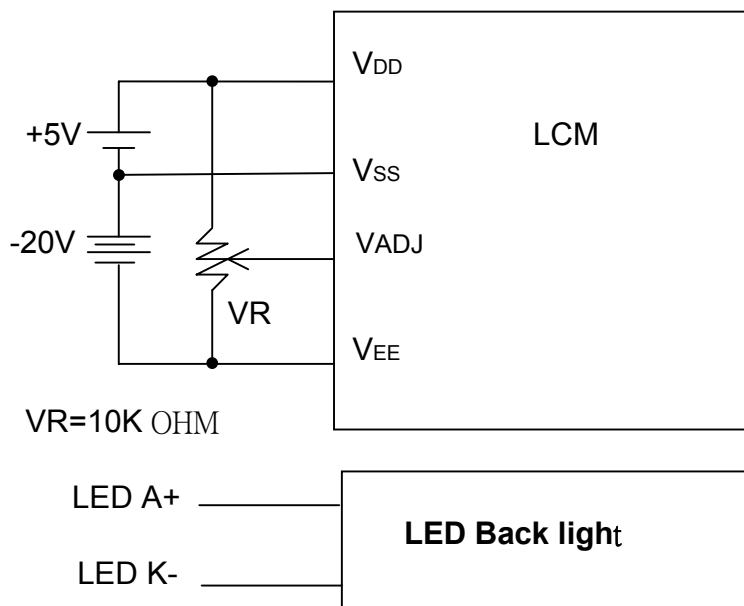

10. BLOCK DIAGRAM

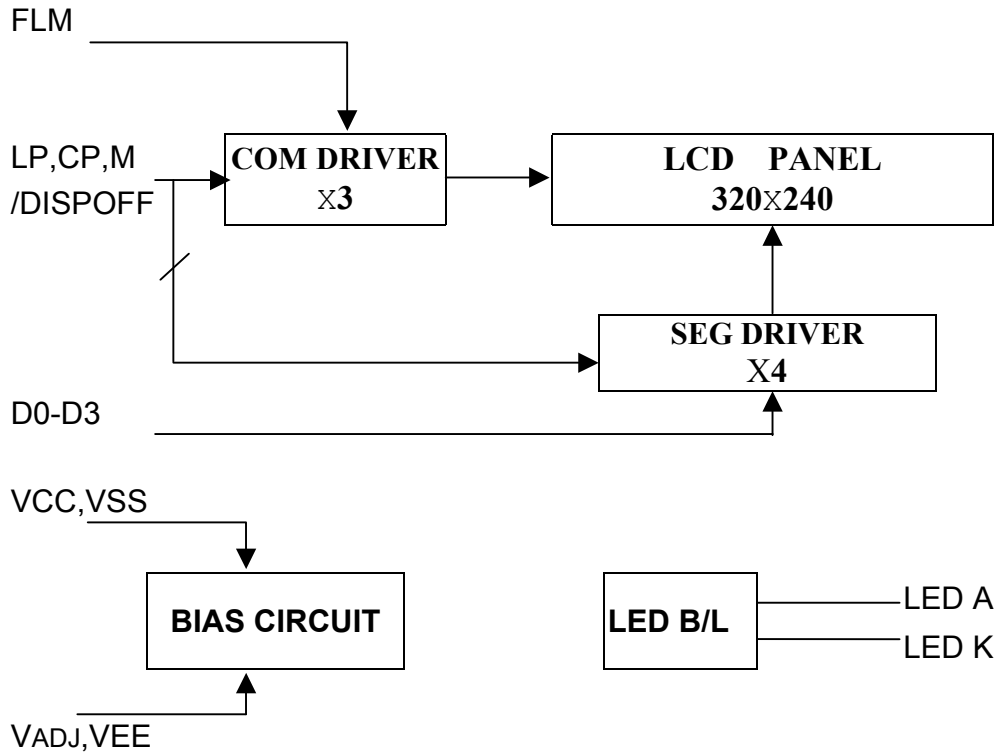

11. QUALITY ASSURANCE

11.1 Test Condition

11.1.1 Temperature and Humidity(Ambient Temperature)

11.1.2 Temperature : $20 \pm 5^{\circ}\text{C}$
Humidity : $65 \pm 5\%$

11.1.3 Operation

Unless specified otherwise, test will be conducted under function state.

11.1.4 Container

Unless specified otherwise, vibration test will be conducted to the product itself without putting it in a container.

11.1.5 Test Frequency

In case of related to deterioration such as shock test. It will be conducted only once.

11.1.6 Test Method

No.	Parameter	Conditions	Regulations
1	High Temperature Operating	$50 \pm 2^{\circ}\text{C}$	Note 3
2	Low Temperature Operating	$0 \pm 2^{\circ}\text{C}$	Note 3
3	High Temperature Storage	$70 \pm 2^{\circ}\text{C}$	Note 3
4	Low Temperature Storage	$-20 \pm 2^{\circ}\text{C}$	Note 3
5	Vibration Test (Non-operation state)	Total fixed amplitude : 1.5mm Vibration Frequency : 10 ~ 55Hz One cycle 60 seconds to 3 directions of X.Y.Z. for each 15 minutes	Note 3
6	Damp Proof Test (Non-operation state)	$40^{\circ}\text{C} \pm 2^{\circ}\text{C}$, 90~95%RH, 96h	Note 1,2
7	Shock Test (Non-operation state)	To be measured after dropping from 60cm high once concrete surface in packing state	Note 3

Note 1: Returned under normal temperature and humidity for 4 hrs.

Note 2: No dew condensation to be observed.

Note 3: No change on display and in operation under the test condition

11.2 Inspection condition

11.2.1 Inspection conditions

The LCD shall be inspected under 40W white fluorescent light.

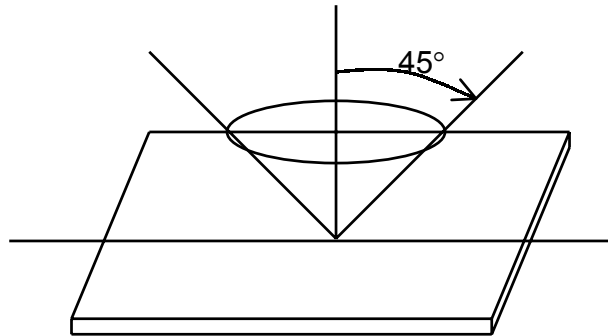

11.2.2 Definition of applicable Zones

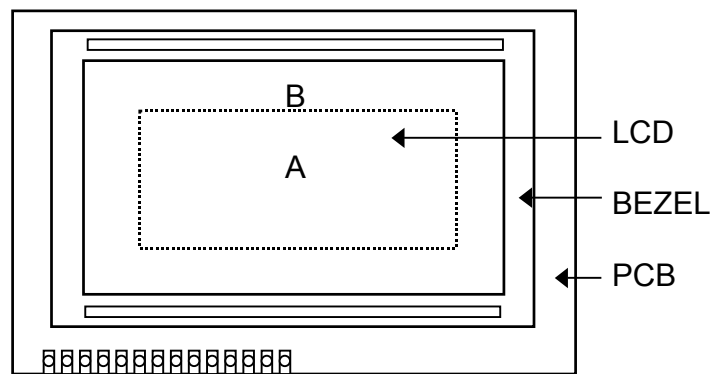

A : Display Area
B : Non-Display Area

11.2.3 Inspection Parameters

No.	Parameter	Criteria																												
1	Black or White spots	<table border="1"> <thead> <tr> <th rowspan="2">Zone Dimension</th> <th colspan="2">Acceptable number</th> <th rowspan="2">Class Of Defects</th> <th rowspan="2">AQL Level</th> </tr> <tr> <th>A</th> <th>B</th> </tr> </thead> <tbody> <tr> <td>D < 0.15</td> <td>*</td> <td>*</td> <td rowspan="4">Minor</td> <td rowspan="4">2.5</td> </tr> <tr> <td>0.15 ≤ D < 0.2</td> <td>4</td> <td>4</td> </tr> <tr> <td>0.2 ≤ D ≤ 0.25</td> <td>2</td> <td>2</td> </tr> <tr> <td>D ≤ 0.3</td> <td>0</td> <td>1</td> </tr> </tbody> </table> <p style="text-align: center;">D = (Long + Short) / 2 * : Disregard</p>	Zone Dimension	Acceptable number		Class Of Defects	AQL Level	A	B	D < 0.15	*	*	Minor	2.5	0.15 ≤ D < 0.2	4	4	0.2 ≤ D ≤ 0.25	2	2	D ≤ 0.3	0	1							
Zone Dimension	Acceptable number			Class Of Defects	AQL Level																									
	A	B																												
D < 0.15	*	*	Minor	2.5																										
0.15 ≤ D < 0.2	4	4																												
0.2 ≤ D ≤ 0.25	2	2																												
D ≤ 0.3	0	1																												
2	Scratch, Substances	<table border="1"> <thead> <tr> <th colspan="2">Zone</th> <th colspan="2">Acceptable number</th> <th rowspan="2">Class Of Defects</th> <th rowspan="2">AQL Level</th> </tr> <tr> <th>X (mm)</th> <th>Y(mm)</th> <th>A</th> <th>B</th> </tr> </thead> <tbody> <tr> <td>*</td> <td>0.04 ≥ W</td> <td>*</td> <td>*</td> <td rowspan="4">Minor</td> <td rowspan="4">2.5</td> </tr> <tr> <td>3.0 ≥ L</td> <td>0.06 ≥ W</td> <td>4</td> <td>4</td> </tr> <tr> <td>2.0 ≥ L</td> <td>0.08 ≥ W</td> <td>2</td> <td>3</td> </tr> <tr> <td>—</td> <td>0.1 < W</td> <td>0</td> <td>1</td> </tr> </tbody> </table> <p style="text-align: center;">X : Length Y : Width * : Disregard Total defects should not exceed 4/module</p>	Zone		Acceptable number		Class Of Defects	AQL Level	X (mm)	Y(mm)	A	B	*	0.04 ≥ W	*	*	Minor	2.5	3.0 ≥ L	0.06 ≥ W	4	4	2.0 ≥ L	0.08 ≥ W	2	3	—	0.1 < W	0	1
Zone		Acceptable number		Class Of Defects	AQL Level																									
X (mm)	Y(mm)	A	B																											
*	0.04 ≥ W	*	*	Minor	2.5																									
3.0 ≥ L	0.06 ≥ W	4	4																											
2.0 ≥ L	0.08 ≥ W	2	3																											
—	0.1 < W	0	1																											
3	Air Bubbles (between glass & polarizer)	<table border="1"> <thead> <tr> <th rowspan="2">Zone Dimension</th> <th colspan="2">Acceptable number</th> <th rowspan="2">Class of Defects</th> <th rowspan="2">AQL Level</th> </tr> <tr> <th>A</th> <th>B</th> </tr> </thead> <tbody> <tr> <td>D ≤ 0.15</td> <td>*</td> <td>*</td> <td rowspan="3">Minor</td> <td rowspan="3">2.5</td> </tr> <tr> <td>0.15 < D ≤ 0.25</td> <td>2</td> <td>*</td> </tr> <tr> <td>0.25 < D</td> <td>0</td> <td>1</td> </tr> </tbody> </table> <p style="text-align: center;">* : Disregard Total defects shall not excess 3/module.</p>	Zone Dimension	Acceptable number		Class of Defects	AQL Level	A	B	D ≤ 0.15	*	*	Minor	2.5	0.15 < D ≤ 0.25	2	*	0.25 < D	0	1										
Zone Dimension	Acceptable number			Class of Defects	AQL Level																									
	A	B																												
D ≤ 0.15	*	*	Minor	2.5																										
0.15 < D ≤ 0.25	2	*																												
0.25 < D	0	1																												
4	Uniformity of Pixel	<p>(1) Pixel shape (with Dent)</p>																												

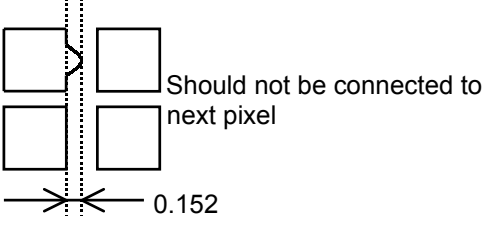
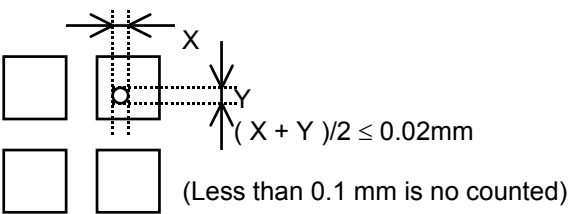
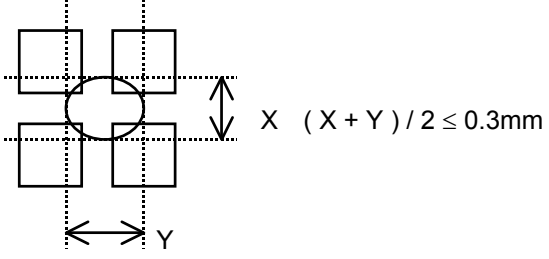
4	Uniformity of Pixel	<p>(2) Pixel shape (with Projection)</p>  <p>Should not be connected to next pixel</p> <p>0.152</p>	
		<p>(3) Pin hole</p>  <p>$(X + Y) / 2 \leq 0.02\text{mm}$</p> <p>(Less than 0.1 mm is no counted)</p>	
		<p>(4) Deformation</p>  <p>$(X + Y) / 2 \leq 0.3\text{mm}$</p> <p>Total acceptable number : 1/pixel, 5/cell</p>	
Class of defects	Major	AQL 0.65%	Definition
		AQL 1.00%	It is a defect that is likely to result in failure or to reduce materially the usability of the product for the intended function.
	Minor	AQL 2.5%	It is a defect that is likely to assembly size and not result in functioning problem.
		It is a defect that will not result in functioning problem with deviation classified.	

11.3 Sampling Condition

Unless otherwise agree in written, the sampling inspection shall be applied to the incoming inspection of customer.

Lot size: Quantity of shipment lot per model.

Sampling type: normal inspection, single sampling

Sampling table: MIL-STD-105E

Inspection level: Level II

12. LOT NUMBERING SYSTEM

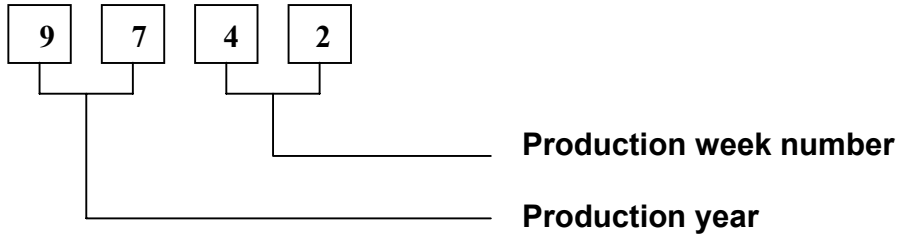

13. LCM NUMBERING SYSTEM

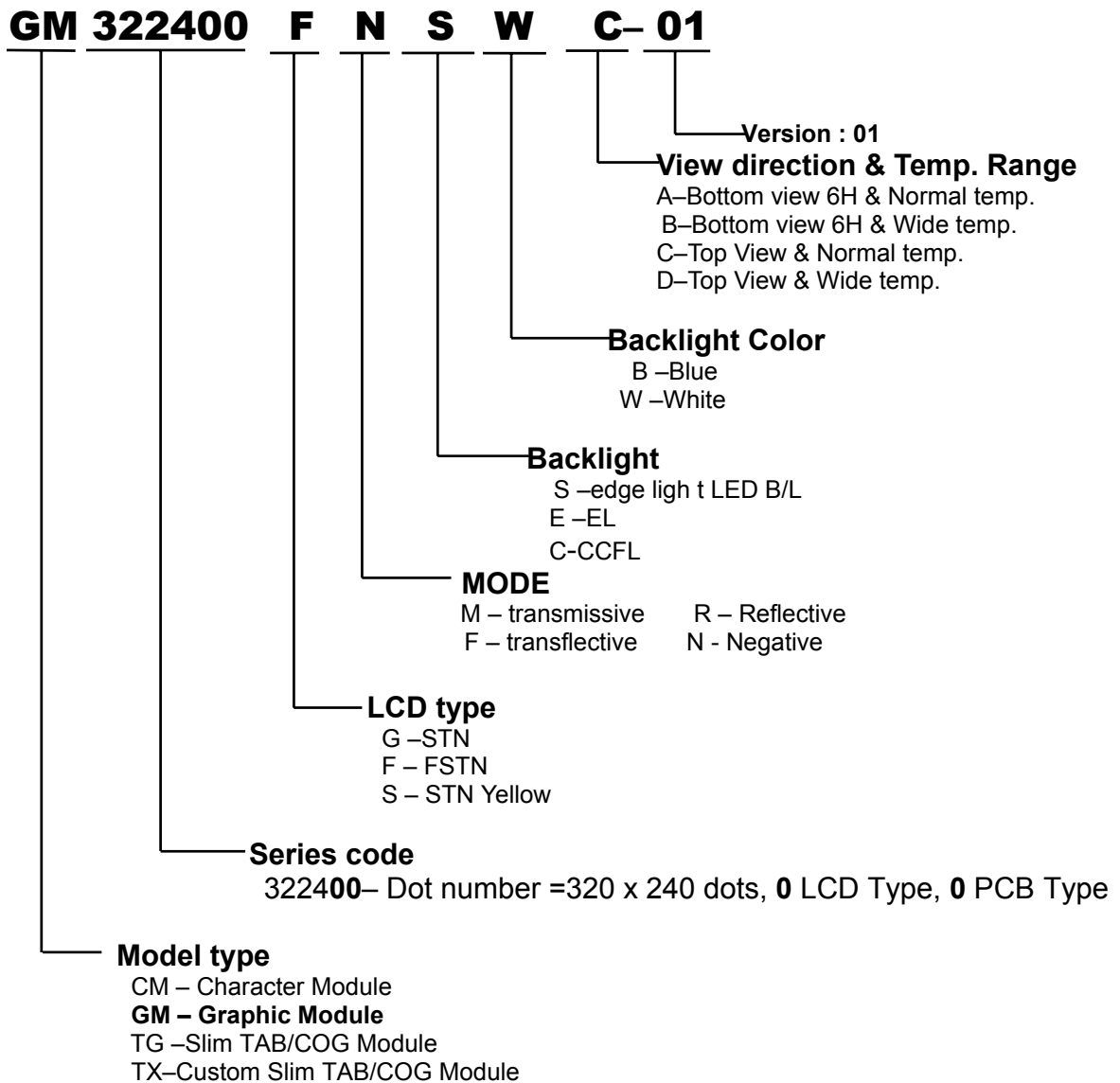

14. PRECAUTION FOR USING LCM

1. LIQUID CRYSTAL DISPLAY (LCD)

LCD is made up of glass, organic sealant, organic fluid, and polymer based polarizers. The following precautions should be taken when handling,

- (1). Keep the temperature within range of use and storage. Excessive temperature and humidity could cause polarization degradation, polarizer peel off or bubble.
- (2). Do not contact the exposed polarizers with anything harder than an HB pencil lead. To clean dust off the display surface, wipe gently with cotton, chamois or other soft material soaked in petroleum benzin.
- (3). Wipe off saliva or water drops immediately. Contact with water over a long period of time may cause polarizer deformation or color fading, while an active LCD with water condensation on its surface will cause corrosion of ITO electrodes.
- (4). Glass can be easily chipped or cracked from rough handling, especially at corners and edges.
- (5). Do not drive LCD with DC voltage.

2. Liquid Crystal Display Modules

2.1 Mechanical Considerations

LCM are assembled and adjusted with a high degree of precision. Avoid excessive shocks and do not make any alterations or modifications. The following should be noted.

- (1). Do not tamper in any way with the tabs on the metal frame.
- (2). Do not modify the PCB by drilling extra holes, changing its outline, moving its components or modifying its pattern.
- (3). Do not touch the elastomer connector, especially insert an backlight panel (for example, EL).
- (4). When mounting a LCM make sure that the PCB is not under any stress such as bending or twisting. Elastomer contacts are very delicate and missing pixels could result from slight dislocation of any of the elements.
- (5). Avoid pressing on the metal bezel, otherwise the elastomer connector could be deformed and lose contact, resulting in missing pixels.

2.2. Static Electricity

LCM contains CMOS LSI's and the same precaution for such devices should apply, namely

- (1). The operator should be grounded whenever he/she comes into contact with the module. Never touch any of the conductive parts such as the LSI pads, the copper leads on the PCB and the interface terminals with any parts of the human body.
- (2). The modules should be kept in antistatic bags or other containers resistant to static for storage.
- (3). Only properly grounded soldering irons should be used.
- (4). If an electric screwdriver is used, it should be well grounded and shielded from commutator sparks.

(5) The normal static prevention measures should be observed for work clothes and working benches; for the latter conductive (rubber) mat is recommended.

(6). Since dry air is inductive to statics, a relative humidity of 50-60% is recommended.

2.3 Soldering

- (1). Solder only to the I/O terminals.
- (2). Use only soldering irons with proper grounding and no leakage.
- (3). Soldering temperature : $280^{\circ}\text{C} \pm 10^{\circ}\text{C}$
- (4). Soldering time: 3 to 4 sec.
- (5). Use eutectic solder with resin flux fill.
- (6). If flux is used, the LCD surface should be covered to avoid flux spatters. Flux residue should be removed after wards.

2.4 Operation

- (1). The viewing angle can be adjusted by varying the LCD driving voltage V0.
- (2). Driving voltage should be kept within specified range; excess voltage shortens display life.
- (3). Response time increases with decrease in temperature.
- (4). Display may turn black or dark blue at temperatures above its operational range; this is (however not pressing on the viewing area) may cause the segments to appear "fractured".
- (5). Mechanical disturbance during operation (such as pressing on the viewing area) may cause the segments to appear "fractured".

2.5 Storage

If any fluid leaks out of a damaged glass cell, wash off any human part that comes into contact with soap and water. Never swallow the fluid. The toxicity is extremely low but caution should be exercised at all the time.

2.6 Limited Warranty

Unless otherwise agreed between DATA IMAGE and customer, DATA IMAGE will replace or repair any of its LCD and LCM which is found to be defective electrically and visually when inspected in accordance with DATA IMAGE acceptance standards, for a period on one year from date of shipment. Confirmation of such date shall be based on freight documents. The warranty liability of DATA IMAGE is limited to repair and/or replacement on the terms set forth above. DATA IMAGE will not responsible for any subsequent or consequential events.

15. OUTLINE DRAWING

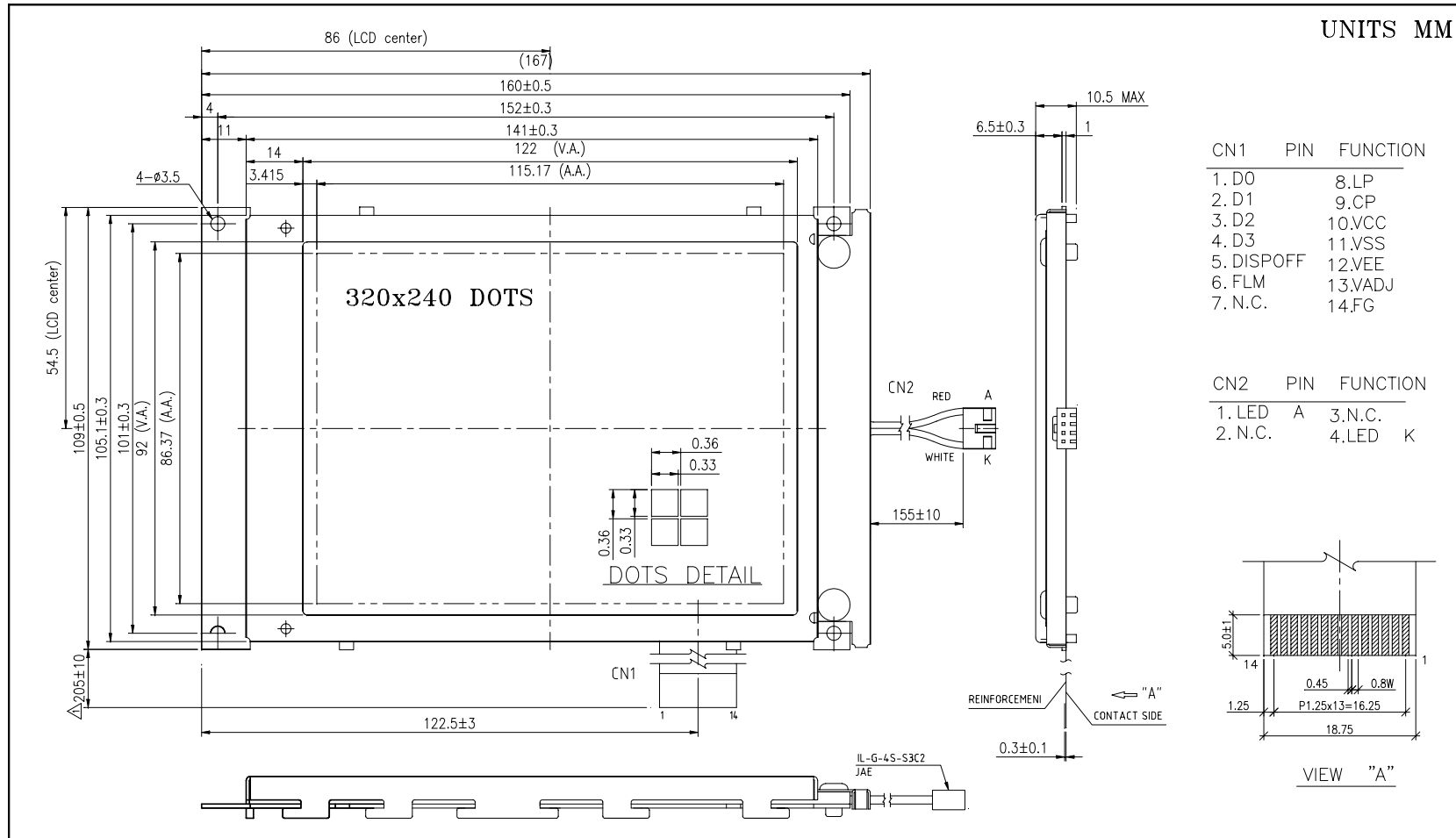

UNITS MM

CN1	PIN	FUNCTION
1.	D0	8.LP
2.	D1	9.CP
3.	D2	10.VCC
4.	D3	11.VSS
5.	DISPOFF	12.VEE
6.	FLM	13.VADJ
7.	N.C.	14.FG

CN2	PIN	FUNCTION
1.	LED A	3.N.C.
2.	N.C.	4.LED K

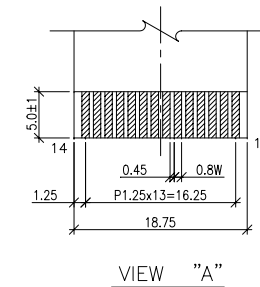

				ISSUE DATE:	12/26/02'	DATA IMAGE Corporation	
				DRAWN:		TITLE: LCM OUTLINE DIMENSION	
				CHECK:		A4 DWG. NO. Q021211	
				APPROVE:		PART. NO. GM322400S1-P REV. B	
REVISIONS				SCALE : NIL		SHEET 1 OF 1	
△	Change FFC tolerancem form ±5 to ±10	02/25/03'					
AUTH	DESCRIPTION	DATE	APPROVED				

16. PACKAGE INFORMATION

