

DATA IMAGE CORPORATION

LCD Module Specification

ITEM NO.: GM163200SFAYB-01

Table of Contents

1. COVER & CONTENTS	1
2. REVISION HISTORY	2
3. GENERAL SPECIFICATIONS	3
4. ABSOLUTE MAXIMUM RATINGS	4
5. ELECTRICAL CHARACTERISTICS	6
6. ELECTRO-OPTICAL CHARACTERISTICS	6
7. TIMING CHARACTERISTICS	9
8. PIN CONNECTIONS	11
9. POWER SUPPLY	11
10. BLOCK DIAGRAM	12
11. QUALITY ASSURANCE	15
12. LOT NUMBERING SYSTEM	19
13. LCM NUMBERING SYSTEM	19
14. PRECAUTIONS IN USE LCM	20
15. OUTLINE DRAWING	21
16. PACKAGE INFORMATION	22

R&D Dept.	Q.C. Dept.	Eng. Dept.	Prod. Dept.
王程吉	Murphy	蔡鴻裕	Ken
Version:	Issued Date:	Sheet Code:	Total Pages:
	2002/7/22		22

2. RECORD OF REVISION

Rev	Date	Item	Page	Comment
	JUL/22/02	13	19	Change: P/N from GM16321BS1LYH-02 to GM163200SFAYB-01.

3. GENERAL SPECIFICATIONS

Display Format : 160 (W) × 32 (H) DOTS
Dot Size : 0.55 (W) × 0.55 (H) mm
Dot Pitch 0.59 (W) × 0.59 (H) mm
View Area : 99 (W) × 24 (H) mm
General Dimensions : 116 (W) × 44 (H) × 14 (T) mm Max.
Weight : 60 g max.

LCD Type : STN Gray STN Yellow FSTN

Polarizer mode : Reflective Transflective

Transmissive Negative

View Angle : 6 O'clock 12 O'clock Others _____

Backlight : LED EL CCFL

Backlight Color : Yellow green Amber Blue Green

White Others

Controller / Driver : KS0107/AX6121AAH

Temperature Range : Normal Wide Temperature
Operating 0 to 50°C Operating -20 to 70°C
Storage -20 to 60°C Storage -30 to 80°C

4. ABSOLUTE MAXIMUM RATINGS

4.1 ELECTRICAL ABSOLUTE MAXIMUM RATINGS

$V_{SS} = 0V$, $T_a = 25^\circ C$

Item	Symbol	Min.	Max.	Unit
Supply Voltage (Logic)	VDD-VSS	0	8	V
Supply Voltage (LCD Driver)	VDD-VEE	0	16.5	V
Input Voltage	V_i	$V_{SS}-0.3$	$V_{DD}+0.3$	V
Operating Temperature	T_{OP}	-20	70	$^\circ C$
Storage Temperature	T_{STG}	-30	80	$^\circ C$

4.2 ENVIRONMENTAL ABSOLUTE MAXIMUM RATINGS

Item	Operating		Storage		Comment
	(Min.)	Max.)	(Min.)	(Max.)	
Ambient Temp	-20	70	-30	80	Note (1)
Humidity	Note (2)		Note(2)		Without Condensation
Vibration	--	4.9M/S ²	--	19.6M/S ²	XYZ Direction
Shock	--	29.4M/S ²	--	490M/S ²	XYZ Direction

Note(1) $T_a = 0^\circ C$: 50Hr Max.

Note(2) $T_a \leq 40^\circ C$: 90% RH Max.

$T_a \geq 40^\circ C$: Absolute humidity must be lower than the humidity of 90% RH at $40^\circ C$.

4.3 Electronic Static Discharge maximum rating

ESD test method : IEC1000-4-2

Item	Description	
Testing environment	Ambient temperature : 15°C to 35 °C Humidity: 30% to 60 % LCM (E.U.T) : Power up	
Testing equipment	Manufacture: NoiseKen, Model No. ESD-100L	
Testing condition	See drawing 1	
Direct discharge	0 to ± 6 KV	Discharge point, see drawing 2
Indirect discharge	0 to ± 12KV	Discharge point, see drawing 1
Pass condition	No malfunction of unit. Temporary malfunction of unit which can be recovered by system reset	
Fail condition	Non. Recoverable malfunction of LCM or system	

FIG 1 ESD TESTING EQUIPMENT

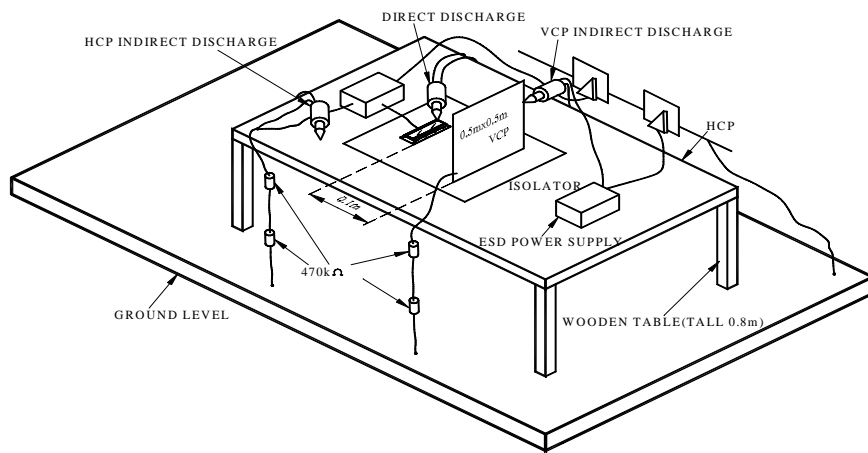

(1)

DIRECT CONTACT DISCHARGE CONTACT POINT : A.B.C.D

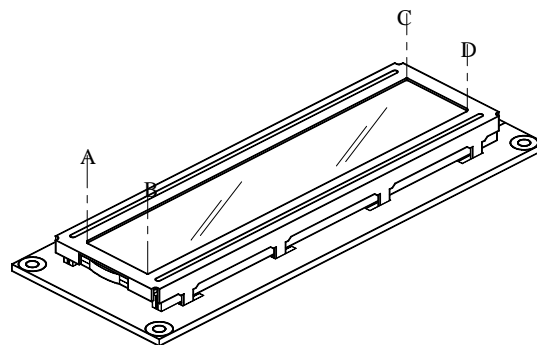

(2)

5. ELECTRICAL CHARACTERISTICS

Item	Symbol	Condition	Min.	Typ.	Max.	Unit
Supply Voltage (Logic)	VDD-VSS		4.5	5.0	5.5	V
Supply Voltage (LCD)	VDD-Vo	-20°C	7.6	8.2	8.8	V
		25°C	6.5	6.9	7.5	
		70°C	6.0	6.3	6.7	
Input Voltage	V _{IH}	--	V _{SS} +2.0	--	V _{DD}	V
	V _{IL}		V _{SS}	--	V _{SS} +0.8	
Logic Supply Current	I _{DD}	VDD-VSS=5V	3.6	3.8	5.0	mA
	I _{EE}		1.4	1.45	2.0	mA

6. ELECTRO-OPTICAL CHARACTERISTICS

ITEM	Symbol	Condition	Min.	Typ.	Max.	Unit	Ref.
Rise Time	Tr	0°C	--	560	650	ms	Note (1)
		25°C		200	320		
Fall Time	Tf	0°C	--	620	780	ms	
		25°C		150	240		
Contrast	CR	25°C	--	3	--		Note (3)
View Angle	θ _{1-θ2} ∅ _{1, ∅2}	25°C & CR≥2	--	-25	--		Note (2)
			--	50	--		
Frame Frequency	Ff	25°C	--	70	--	Hz	

Note (1) & (2) : See next page

Note (3) : Contrast ratio is defined under the following condition:

$$CR = \frac{\text{Brightness of non-selected condition}}{\text{Brightness of selected condition}}$$

- (a). Temperature ----- 25°C
- (b). Frame frequency ---- 70Hz
- (c). Viewing angle ----- θ= 0°, ∅ = 0°
- (d). Operating voltage --- 6.9V

Note (1) Response time is measured as the shortest period of time possible between the change in state of an LCD segment as demonstrated below:

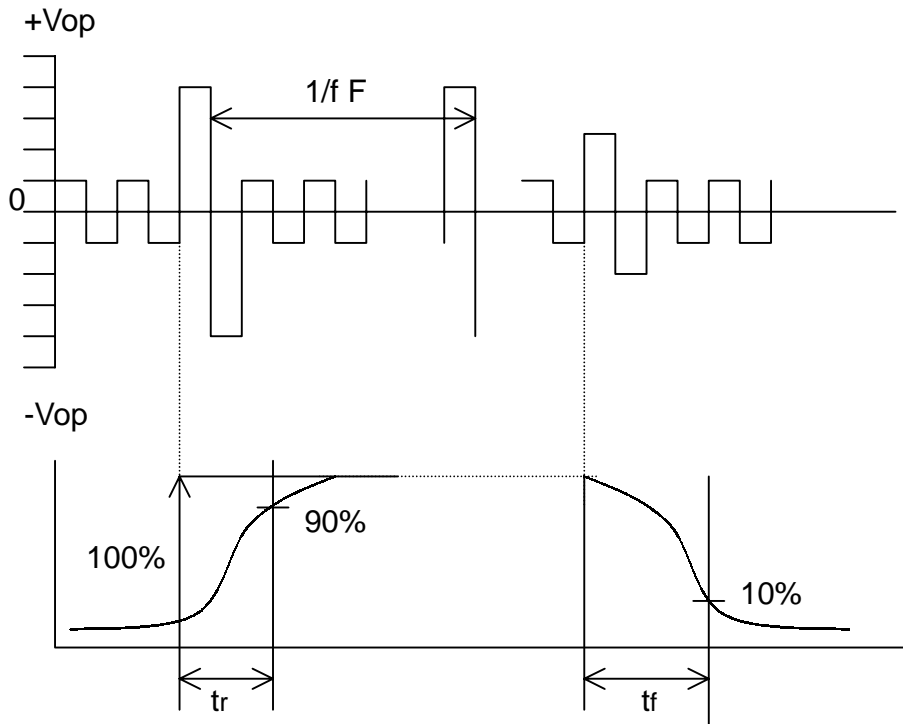

Condition:

- (a) . Temperature ----- $25^{\circ}C$
- (b) . Frame frequency ----- 70Hz
- (c) . View Angle ----- $\theta = 0^{\circ}, \varnothing=0^{\circ}$
- (d) . Operating voltage ----- 6.9V

Note (2) Definition of View Angle

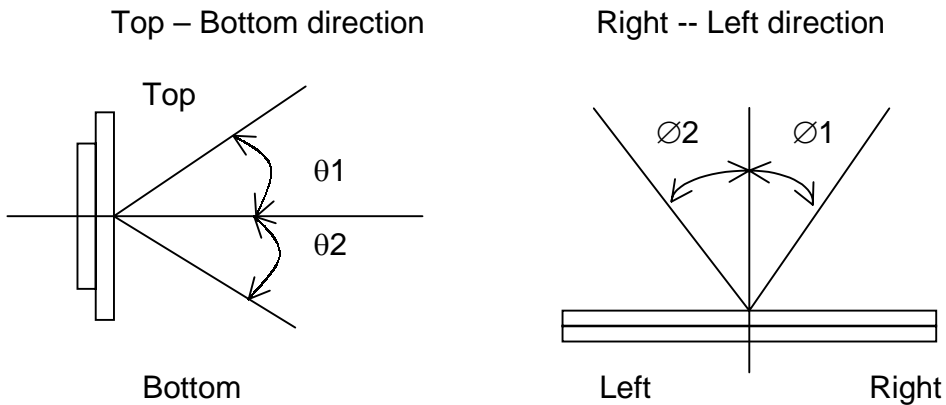

6.1 LED ELECTRO-OPTICAL CHARACTERISTIC

Ta = 25°C

Item	Symbol	Condition	Min.	Typ.	Max.	Unit
Forward Voltage	V _F	IF = 310mA Yellow Green	--	4.2	4.6	V
Luminous Intensity	I _V	IF = 310mA Yellow Green	70	140	--	cd/m ²
Peak Emission	λ _P	IF = 310mA Yellow Green	--	570	--	nm
Spectrum Radiation	Δλ	IF = 310mA Yellow Green	--	30	--	nm
Reverse Current	I _R	VR = 8V Yellow Green	--	--	0.2	mA

Note : Measured at the LED backlight unit.

6.2 LED MAXIMUM OPERATING RANGE

Item	Symbol	Yellow Green	Unit
Power Dissipation	P _{AD}	1.8	W
Forward Current	I _{AF}	420	mA
Reverse Voltage	V _R	8	V

6.2.1 LED ARRAY BLOCK DIAGRAM

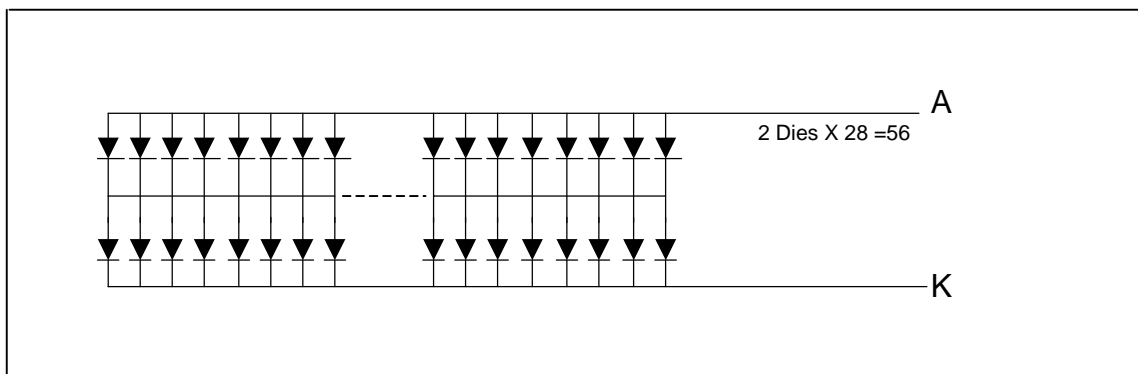

7. TIMING CHARACTERISTICS

AC Characteristics

MPU Bus Read/Write I (80 – family MPU)

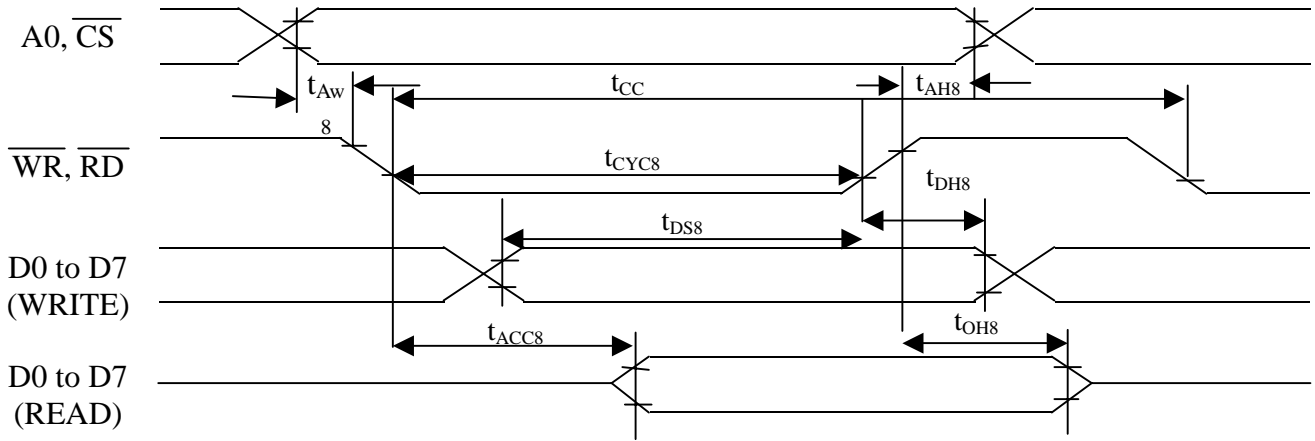

Ta = -20 to 75 deg. C, VSS = -5.0V ± 10% unless stated otherwise

Parameter	Symbol	Condition	Rating		Unit	Signal
			min	max		
Address hold time	t_{AH8}		10	--	ns	A0,CS
Address setup time	t_{AW8}		20	--	ns	
System cycle time	t_{CYC8}		1000	--	ns	WR,RD
Control pulsewidth	t_{CC}		200	--	ns	
Data setup time	t_{DS8}		80	--	ns	D0 to D7
Data hold time	t_{DH8}		10	--	ns	
RD access time	t_{ACC8}	CL = 100 PF	--	90	ns	
Output disable time	t_{CH8}		10	60	ns	

Notes : 1. Increase parameter values by 200% when Vss = -3.0V.

2. All inputs must have a rise and fall time of less than 15 ns.

MPU Bus Read/Write II (68 – family MPU)

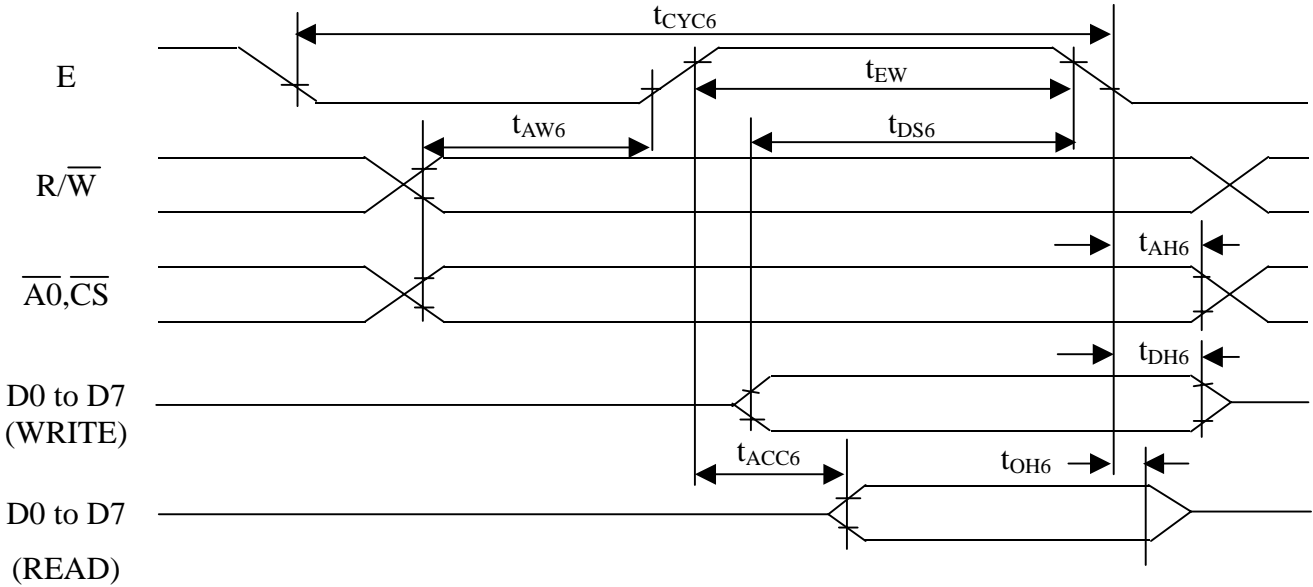

Ta = -20 to 75 deg. C, VSS = -5.0V ± 10% unless stated otherwise

Parameter	Symbol	Condition	Rating		Unit	Signal
			min	max		
System cycle time	t _{CYC6}		1000	--	ns	A0, CS, R/W
Address setup time	t _{AW6}		20	--	ns	
Address hold time	t _{AH6}		00	--	ns	
Data setup time	t _{DS6}		80	--	ns	D0 to D7
Data hold time	t _{DH6}		10	--	ns	
Output disable time	t _{OH6}	CL = 100 PF	10	60	ns	
Access time	t _{ACC6}		--	90	ns	
Enable pulsewidth	Read	t _{EW}	100	--	ns	E
	Write		8	--	ns	

- Notes :
1. t_{CYC6} is the cycle time of CS. E = H, not the cycle time of E.
 2. Increase parameter values by 200% when V_{SS} = -3.0V.
 3. All inputs must have a rise and fall time of less than 15 ns.

8. PIN CONNECTIONS

No.	Symbol	Function
1	AO	Instructions (L) or Data (H)
2	/CS2	Chip Enable Active "L"
3	/CS1	Chip Enable Active "L"
4	/RD(E)	/RD For 80 Serial, E For 68 Serial
5	/WR(R/W)	/WR For 80 Serial,R/W For 68 Serial
6	VDD	Power supply for Circuit
7	VSS	Ground
8-15	DB0-DB7	Data Bus Line
16	RES	"H" to "L"=80 Series , "L" to "H"=60 Series
17	VO	Power Supply For LCD Drive
18	VEE	Negative Voltage input.
19	LED A	LED Anode (Power supply +)
20	LED K	LED Cathode (Power supply -)

9. POWER SUPPLY

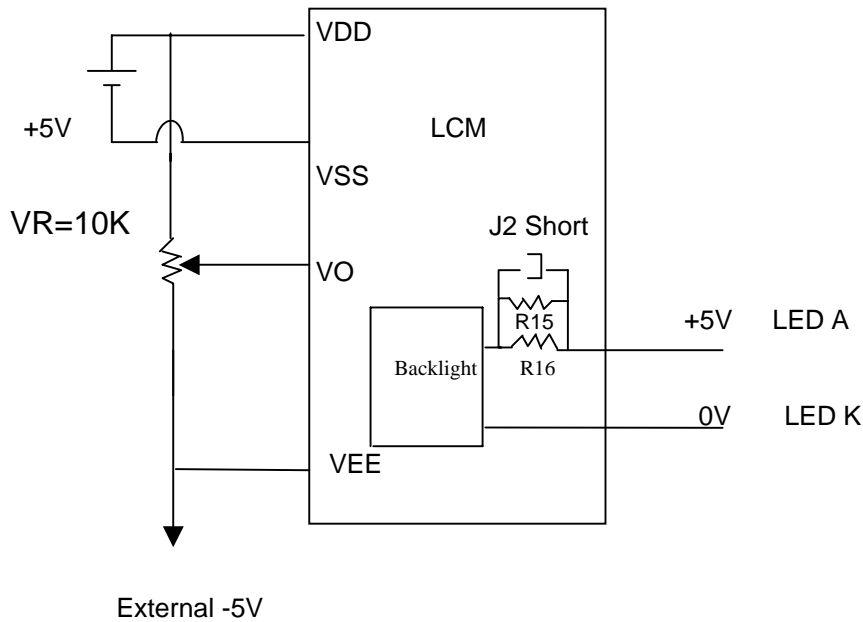

10. BLOCK DIAGRAM

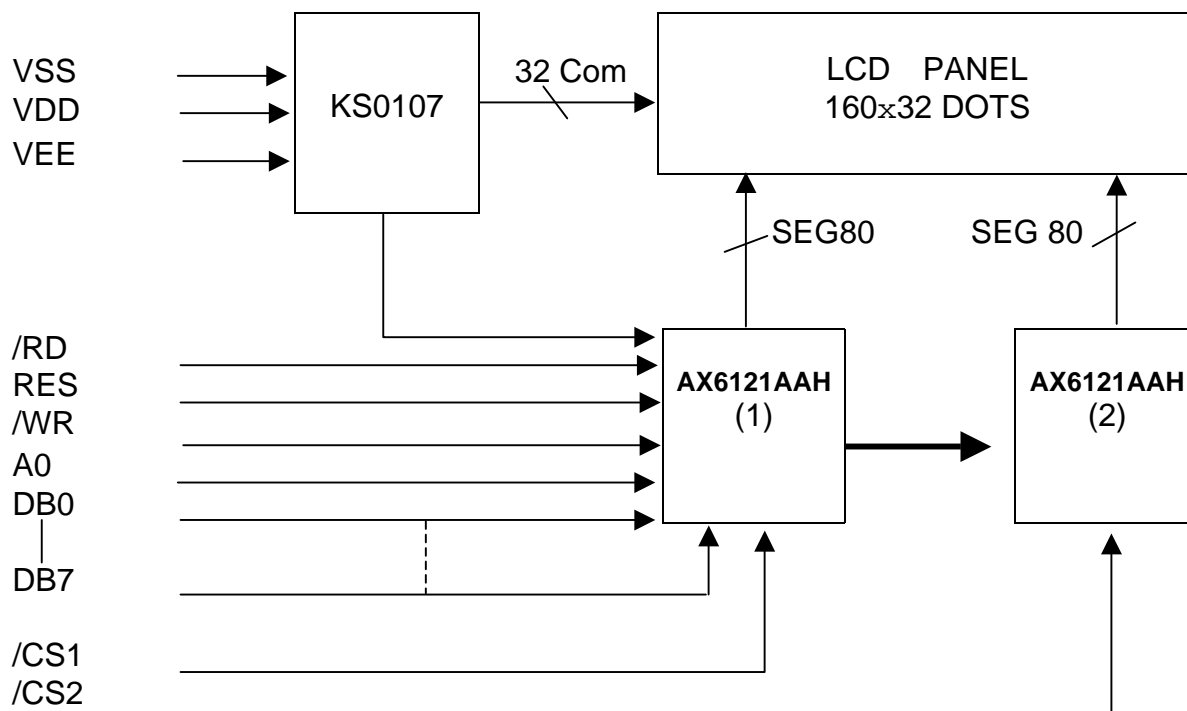

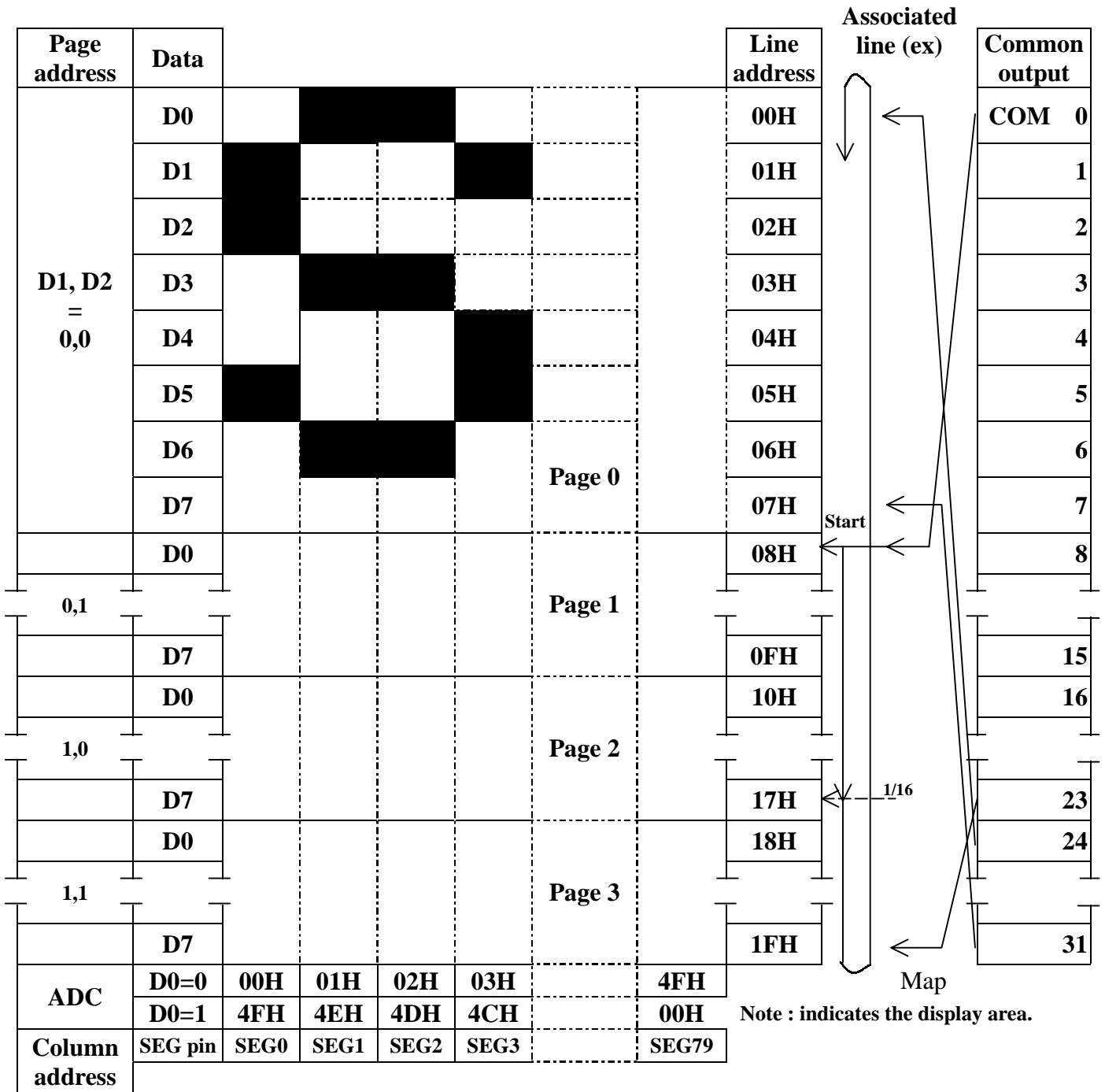

Display Data RAM Addressing

COMMANDS

Summary

Command	Code											Function	
	A0	RD	WR	D7	D6	D5	D4	D3	D2	D1	D0		
Display ON/OFF	0	1	0	1	0	1	0	1	1	1	0/1	Turns display on or off. 1 : ON, 0 : OFF	
Display start line	0	1	0	1	1	0	Display start address (0 to 31)					Specifies RAM line corresponding to top line of display.	
Set page address	0	1	0	1	0	1	1	1	0	Page (0 to 3)		Sets display RAM page in page address register.	
Set column (segment) address	0	1	0	0	Column address (0 to 72)							Sets display RAM column address in column address register.	
Read status	0	0	1	Busy	ADC	ON/OFF	Reset	0	0	0	0	Reads the following status:	
												BUSY	1 : Busy 0 : Ready
												ADC	1 : CW output 0 : CCW output
												ON/OFF	1 : Display off 0 : Display on
RESET	1 : Being reset 0 : Normal												
Write display data	1	1	0	Write data							Writes data from data bus into display RAM.		
Read display data	1	0	1	Read data							Reads data from display RAM onto data bus.		
Select ADC	0	1	0	1	0	1	0	0	0	0	0/1	0 : CW output 1 : CCW output	
Static drive ON/OFF	0	1	0	1	0	1	0	0	1	0	0/1	Selects static driving operation. 1 : Static drive 0 : Normal driving	
Select duty	0	1	0	1	0	1	0	1	0	0	0/1	Selects LCD duty cycle 1 : 1/32 0 : 1/16	
Read – Modify - Write	0	1	0	1	1	1	0	0	0	0	0	Read – modify – write ON	
End	0	1	0	1	1	1	0	1	1	1	0	Read – modify – write OFF	
Reset	0	1	0	1	1	1	0	0	0	1	0	Software reset	

11. QUALITY ASSURANCE

11.1 Test Condition

11.1.1 Temperature and Humidity(Ambient Temperature)

Temperature : $20 \pm 5^{\circ}\text{C}$

Humidity : $65 \pm 5\%$

11.1.2 Operation

Unless specified otherwise, test will be conducted with LCM in operation.

11.1.3 Container

Unless specified otherwise, vibration test will be conducted on module only.

11.1.4 Test Frequency

Single cycle.

11.1.5 Test Method

No.	Parameter	Conditions	Regulations
1	High Temperature Operating	$70 \pm 2^{\circ}\text{C}$	Note 3
2	Low Temperature Operating	$-20 \pm 2^{\circ}\text{C}$	Note 3
3	High Temperature Storage	$80 \pm 2^{\circ}\text{C}$	Note 3
4	Low Temperature Storage	$-30 \pm 2^{\circ}\text{C}$	Note 3
5	Vibration Test (Non-operation state)	Total fixed amplitude : 1.5mm Vibration Frequency : 10 ~ 55Hz One cycle 60 seconds to 3 directions of X.Y.Z. for each 15 minutes	Note 3
6	Damp Proof Test (Non-operation state)	$40^{\circ}\text{C} \pm 2^{\circ}\text{C}$, 90~95%RH, 96h	Note 1,2
7	Shock Test (Non-operation state)	To be measured after dropping from 60cm high once concrete surface in packing state	Note 3

Note 1: Returned under normal temperature and humidity for 4 hrs.

Note 2: No dew condensation to be observed.

Note 3: No change on display and in operation under the test condition

11.2 Inspection condition

11.2.1 Inspection conditions

The LCD shall be inspected under 40W white fluorescent light.

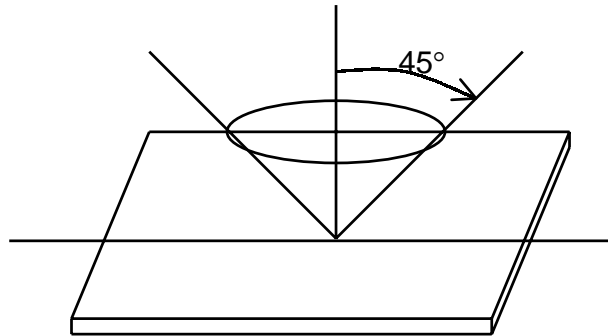

11.2.2 Definition of applicable Zones

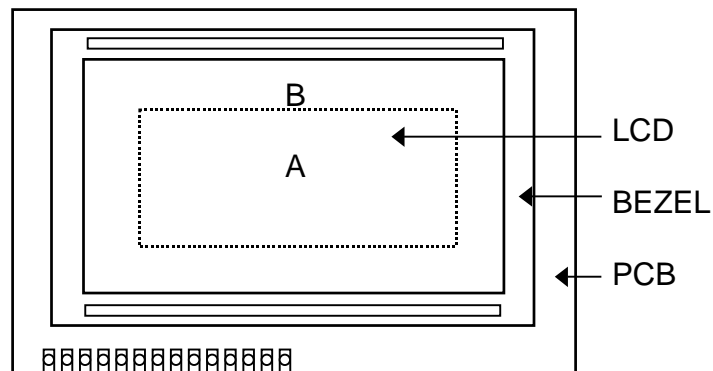

A : Display Area
B : Non-Display Area

11.2.3 Inspection Parameters

No.	Parameter	Criteria																												
1	Black or White spots	<table border="1"> <thead> <tr> <th rowspan="2">Zone Dimension</th> <th colspan="2">Acceptable number</th> <th rowspan="2">Class Of Defects</th> <th rowspan="2">AQL Level</th> </tr> <tr> <th>A</th> <th>B</th> </tr> </thead> <tbody> <tr> <td>D < 0.15</td> <td>*</td> <td>*</td> <td rowspan="4">Minor</td> <td rowspan="4">2.5</td> </tr> <tr> <td>0.15 ≤ D < 0.2</td> <td>4</td> <td>4</td> </tr> <tr> <td>0.2 ≤ D ≤ 0.25</td> <td>2</td> <td>2</td> </tr> <tr> <td>D ≤ 0.3</td> <td>0</td> <td>1</td> </tr> </tbody> </table> <p>D = (Long + Short) / 2 * : Disregard</p>	Zone Dimension	Acceptable number		Class Of Defects	AQL Level	A	B	D < 0.15	*	*	Minor	2.5	0.15 ≤ D < 0.2	4	4	0.2 ≤ D ≤ 0.25	2	2	D ≤ 0.3	0	1							
Zone Dimension	Acceptable number			Class Of Defects	AQL Level																									
	A	B																												
D < 0.15	*	*	Minor	2.5																										
0.15 ≤ D < 0.2	4	4																												
0.2 ≤ D ≤ 0.25	2	2																												
D ≤ 0.3	0	1																												
2	Scratch, Substances	<table border="1"> <thead> <tr> <th colspan="2">Zone</th> <th colspan="2">Acceptable number</th> <th rowspan="2">Class Of Defects</th> <th rowspan="2">AQL Level</th> </tr> <tr> <th>X (mm)</th> <th>Y(mm)</th> <th>A</th> <th>B</th> </tr> </thead> <tbody> <tr> <td>*</td> <td>0.04 ≥ W</td> <td>*</td> <td>*</td> <td rowspan="4">Minor</td> <td rowspan="4">2.5</td> </tr> <tr> <td>3.0 ≥ L</td> <td>0.06 ≥ W</td> <td>4</td> <td>4</td> </tr> <tr> <td>2.0 ≥ L</td> <td>0.08 ≥ W</td> <td>2</td> <td>3</td> </tr> <tr> <td>—</td> <td>0.1 < W</td> <td>0</td> <td>1</td> </tr> </tbody> </table> <p>X : Length Y : Width * : Disregard</p> <p>Total defects should not exceed 4/module</p>	Zone		Acceptable number		Class Of Defects	AQL Level	X (mm)	Y(mm)	A	B	*	0.04 ≥ W	*	*	Minor	2.5	3.0 ≥ L	0.06 ≥ W	4	4	2.0 ≥ L	0.08 ≥ W	2	3	—	0.1 < W	0	1
Zone		Acceptable number		Class Of Defects	AQL Level																									
X (mm)	Y(mm)	A	B																											
*	0.04 ≥ W	*	*	Minor	2.5																									
3.0 ≥ L	0.06 ≥ W	4	4																											
2.0 ≥ L	0.08 ≥ W	2	3																											
—	0.1 < W	0	1																											
3	Air Bubbles (between glass & polarizer)	<table border="1"> <thead> <tr> <th rowspan="2">Zone Dimension</th> <th colspan="2">Acceptable number</th> <th rowspan="2">Class of Defects</th> <th rowspan="2">AQL Level</th> </tr> <tr> <th>A</th> <th>B</th> </tr> </thead> <tbody> <tr> <td>D ≤ 0.15</td> <td>*</td> <td>*</td> <td rowspan="3">Minor</td> <td rowspan="3">2.5</td> </tr> <tr> <td>0.15 < D ≤ 0.25</td> <td>2</td> <td>*</td> </tr> <tr> <td>0.25 < D</td> <td>0</td> <td>1</td> </tr> </tbody> </table> <p>* : Disregard</p> <p>Total defects shall not excess 3/module.</p>	Zone Dimension	Acceptable number		Class of Defects	AQL Level	A	B	D ≤ 0.15	*	*	Minor	2.5	0.15 < D ≤ 0.25	2	*	0.25 < D	0	1										
Zone Dimension	Acceptable number			Class of Defects	AQL Level																									
	A	B																												
D ≤ 0.15	*	*	Minor	2.5																										
0.15 < D ≤ 0.25	2	*																												
0.25 < D	0	1																												

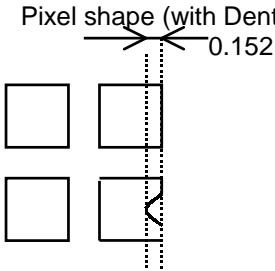
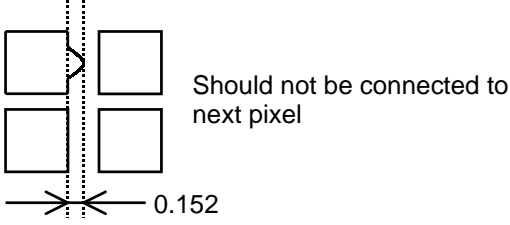
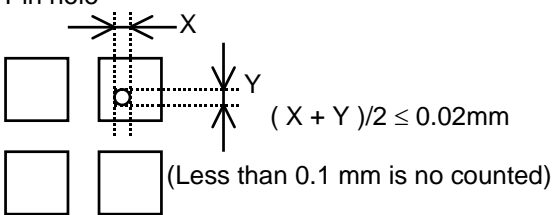
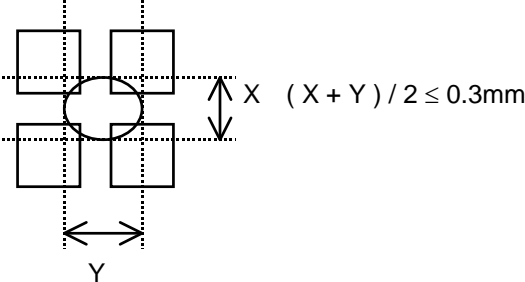
<p>3</p>	<p>Uniformity of Pixel</p>	<p>(1) Pixel shape (with Dent)</p>  <p>(2) Pixel shape (with Projection)</p>  <p>(3) Pin hole</p>  <p>(4) Deformation</p>  <p>Total acceptable number : 1/pixel, 5/cell</p>
----------	----------------------------	--

12. LOT NUMBERING SYSTEM

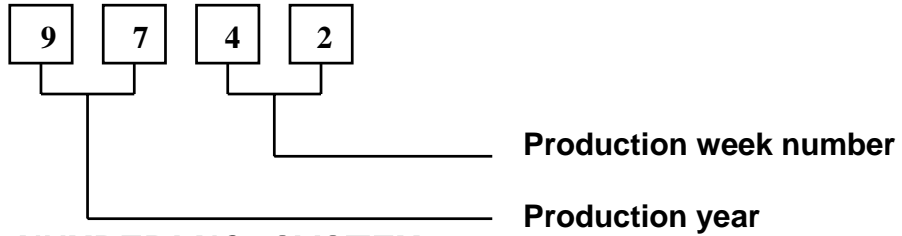

13. LCM NUMBERING SYSTEM

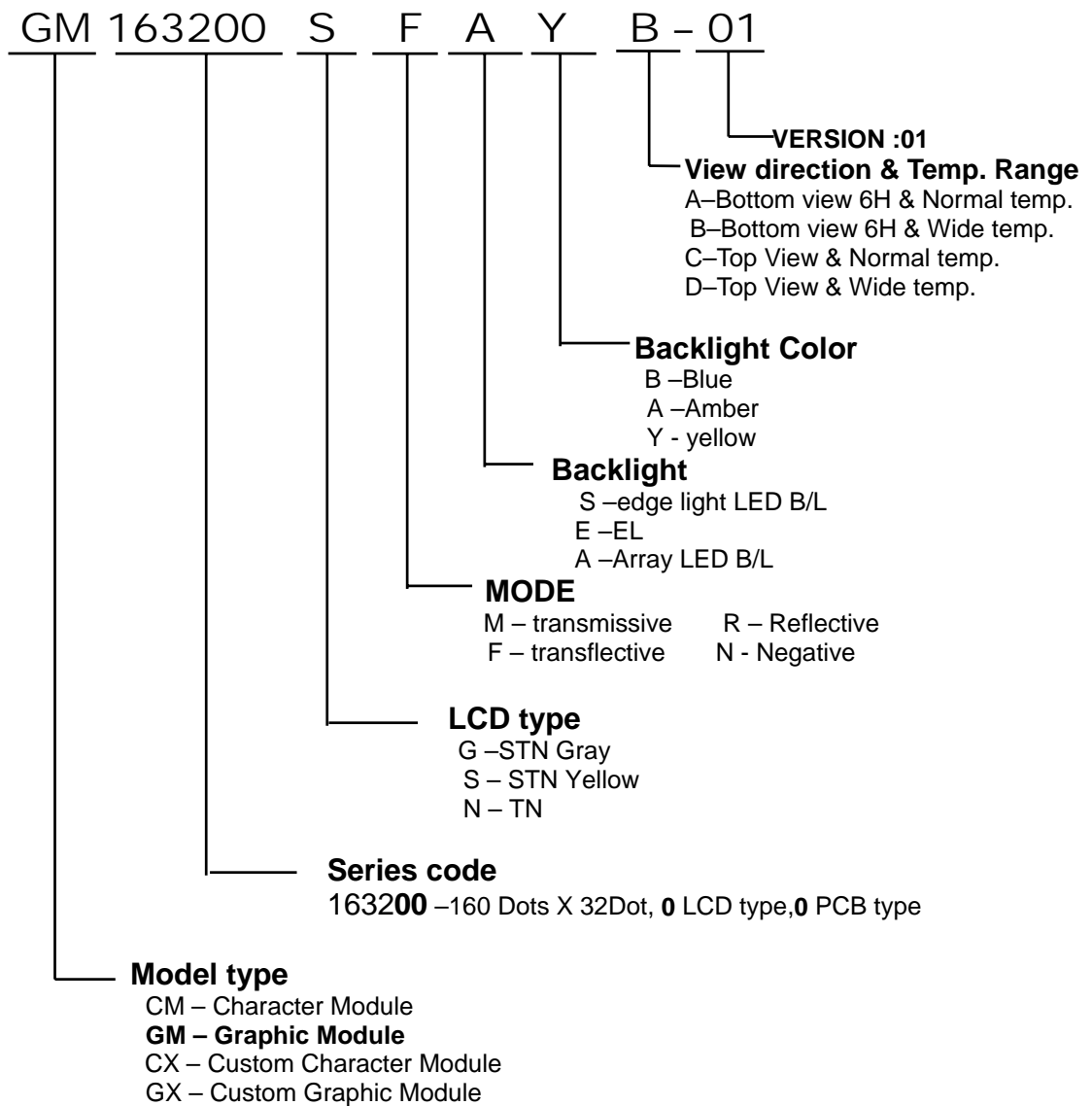

14. PRECAUTION FOR USING LCM

1. LIQUID CRYSTAL DISPLAY (LCD)

LCD is made up of glass, organic sealant, organic fluid, and polymer based polarizers. The following precautions should be taken when handling,

- (1). Keep the temperature within range of use and storage. Excessive temperature and humidity could cause polarization degradation, polarizer peel off or bubble.
- (2). Do not contact the exposed polarizers with anything harder than an HB pencil lead. To clean dust off the display surface, wipe gently with cotton, chamois or other soft material soaked in petroleum benzin.
- (3). Wipe off saliva or water drops immediately. Contact with water over a long period of time may cause polarizer deformation or color fading, while an active LCD with water condensation on its surface will cause corrosion of ITO electrodes.
- (4). Glass can be easily chipped or cracked from rough handling, especially at corners and edges.
- (5). Do not drive LCD with DC voltage.

2. Liquid Crystal Display Modules

2.1 Mechanical Considerations

LCM are assembled and adjusted with a high degree of precision. Avoid excessive shocks and do not make any alterations or modifications. The following should be noted.

- (1). Do not tamper in any way with the tabs on the metal frame.
- (2). Do not modify the PCB by drilling extra holes, changing its outline, moving its components or modifying its pattern.
- (3). Do not touch the elastomer connector, especially insert an backlight panel (for example, EL).
- (4). When mounting a LCM make sure that the PCB is not under any stress such as bending or twisting. Elastomer contacts are very delicate and missing pixels could result from slight dislocation of any of the elements.
- (5). Avoid pressing on the metal bezel, otherwise the elastomer connector could be deformed and lose contact, resulting in missing pixels.

2.2. Static Electricity

LCM contains CMOS LSI's and the same precaution for such devices should apply, namely

- (1). The operator should be grounded whenever he/she comes into contact with the module. Never touch any of the conductive parts such as the LSI pads, the copper leads on the PCB and the interface terminals with any parts of the human body.
- (2). The modules should be kept in antistatic bags or other containers resistant to static for storage.
- (3). Only properly grounded soldering irons should be used.
- (4). If an electric screwdriver is used, it should be well grounded and shielded from commutator sparks.

- (5) The normal static prevention measures should be observed for work clothes and working benches; for the latter conductive (rubber) mat is recommended.
- (6). Since dry air is inductive to statics, a relative humidity of 50-60% is recommended.

2.3 Soldering

- (1). Solder only to the I/O terminals.
- (2). Use only soldering irons with proper grounding and no leakage.
- (3). Soldering temperature : $280^{\circ}\text{C} \pm 10^{\circ}\text{C}$
- (4). Soldering time: 3 to 4 sec.
- (5). Use eutectic solder with resin flux fill.
- (6). If flux is used, the LCD surface should be covered to avoid flux spatters. Flux residue should be removed after wards.

2.4 Operation

- (1). The viewing angle can be adjusted by varying the LCD driving voltage V_0 .
- (2). Driving voltage should be kept within specified range; excess voltage shortens display life.
- (3). Response time increases with decrease in temperature.
- (4). Display may turn black or dark blue at temperatures above its operational range; this is (however not pressing on the viewing area) may cause the segments to appear "fractured".
- (5). Mechanical disturbance during operation (such as pressing on the viewing area) may cause the segments to appear "fractured".

2.5 Storage

If any fluid leaks out of a damaged glass cell, wash off any human part that comes into contact with soap and water. Never swallow the fluid. The toxicity is extremely low but caution should be exercised at all the time.

2.6 Limited Warranty

Unless otherwise agreed between DATA IMAGE and customer, DATA IMAGE will replace or repair any of its LCD and LCM which is found to be defective electrically and visually when inspected in accordance with DATA IMAGE acceptance standards, for a period on one year from date of shipment. Confirmation of such date shall be based on freight documents. The warranty liability of DATA IMAGE is limited to repair and/or replacement on the terms set forth above. DATA IMAGE will not responsible for any subsequent or consequential events.

15 OUTLINE DRAWING

UNITS MM

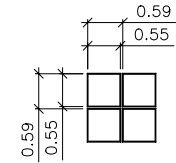
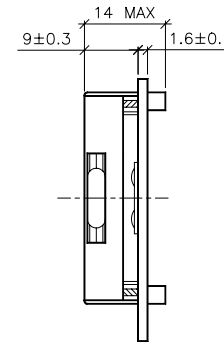
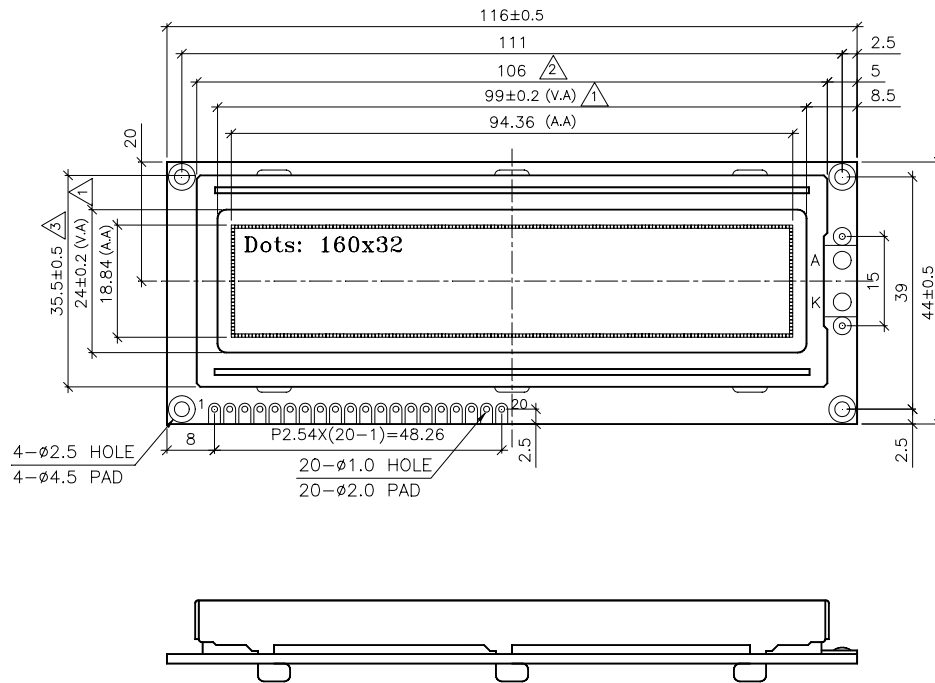

Detail of Dots
Scale 10/1

PIN FUNCTIONS

1. A0	11. DB3
2. /CS2	12. DB4
3. /CS1	13. DB5
4. /RD	14. DB6
5. /WR	15. DB7
6. VDD	16. RES
7. VSS	17. V0
8. DB0	18. VEE
9. DB1	19. LEDA
10. DB2	20. LEDK

Note: tolerance is ± 0.3 unless otherwise noted.

16. PACKAGE INFORMATION

